



*QM1003-0.5-18-X | 0.5 to 18 GHz RF Downconverter, Single (X=1) or Dual (X=2) Channel*

## Typical Applications

- Frequency Conversion
- Laboratory Test Equipment
- Digital Receiver Systems
- Communication systems, SATCOM
- EW, ELINT, SIGINT, Direction Finding
- Wideband systems
- Phased array antenna systems
- Radar systems



**QM1003-0.5-18-2 with Option 100, 200, 1U 19" Rack-Mount**



**QM1003-0.5-18 in Optional Outdoor Unit Form-Factor**

## General Description

The QM1003-0.5-18-X Wideband Downconverter is a frequency agile RF downconverter unit capable of tuning input frequencies centered between 0.5 and 18 GHz with up to 1 GHz of instantaneous bandwidth. The downconverted IF output frequency is typically centered at 1 GHz (OPT 201 - 750 to 1250 MHz), with an optional (OPT 200) third stage to further convert down to 50-550 MHz.

We are now offering 1 GHz bandwidth units with Option 204 centering IF input/output signal from 100-1100 MHz. Option 205 offers IF input/output signal from 2-3 GHz and Option 206 offers IF input/output signal 500-1500 MHz.

## RF Input Frequency Range

QM1003-0.5-18-X      0.5 to 18 GHz

## IF Output Frequency Range

Option 200	50 to 550 MHz
Option 201	750 to 1250 MHz
Option 204	100 to 1100 MHz
Option 205	2000 to 3000 MHz
Option 206	500 to 1500 MHz

## Features

- Single (X=1) or Dual (X=2) channel options
- Base Option 100 provides internal LO generation with USB and TCP/IP control
- Up to 1 GHz instantaneous bandwidth
- Option for external LO tuning
- Independent (110) or common channel frequency control available on dual channel systems
- Frequency agile across entire tunable band

## Form-Factor

- 1U 19" Rack module
- Optional weather-tight outdoor unit (11.81"x16.90"x4.76")



**Quonset Microwave**  
www.quonsetmicrowave.com

## **QM1003-0.5-18-X 0.5-18 GHz Wideband RF Downconverter**

---

QM1003 Series frequency converters now come standard with internally generated LOs (formerly Option 100). A 5 Watt limiter and variable attenuator are included standard at the RF input to the downconversion path. An optional parallel TTL interface is provided on the back panel for fast tuning through a parallel DB-37 connector.

The QM1003-0.5-18-X is controlled via USB or TCP/IP and uses VISA control drivers with the USBTMC protocol, enabling seamless integration into Windows<sup>®</sup>, Linux<sup>®</sup>, and Macintosh<sup>®</sup> environments. A Windows<sup>®</sup> GUI is provided.

All QM1003 Series specifications are customizable upon request. Please contact [sales@quonsetmicrowave.com](mailto:sales@quonsetmicrowave.com) for more information. Detailed performance specifications are also available upon request.



**Quonset Microwave**  
www.quonsetmicrowave.com

**QM1003-0.5-18-X**  
**0.5-18 GHz Wideband RF**  
**Downconverter**

**Electrical Specifications - Option 200**

Parameter	Min.	Typ.	Max.	Units
IF Output Center Frequency	50	300	550	MHz
RF Input Frequency Range	0.5		18	GHz
Instantaneous Usable Bandwidth		500		MHz
IF Ripple (+/- 250 MHz)		5		dB
Gain, 0.5-18 GHz, Atten= 0 dB		45		dB
Noise Figure (NF), Atten= 0 dB		6.8		dB
Input P1dB, 0.5-18 GHz, Atten= 0 dB		-40		dBm
Output P1dB, 0.5-18 GHz, Atten= 0 dB		13		dBm
Phase Noise, 1 KHz Offset		-72		dBc/Hz
Phase Noise, 10 KHz Offset		-77		dBc/Hz
Phase Noise, 100 KHz Offset		-77		dBc/Hz
Phase Noise, 1 MHz Offset		-105		dBc/Hz
Phase Noise, 10 MHz Offset		-117		dBc/Hz
In-Band Spurious, +/- 250 MHz		-50		dBc
SFDR (Two-tone test)		50		dB

For price, delivery, and to place orders, please contact Quonset Microwave:  
315 Commerce Park Road, North Kingstown, RI 02852 Phone: 401-295-0062



**Quonset Microwave**  
www.quonsetmicrowave.com

**QM1003-0.5-18-X**  
**0.5-18 GHz Wideband RF**  
**Downconverter**

**Electrical Specifications - Option 201**

Parameter	Min.	Typ.	Max.	Units
IF Output Center Frequency	750	1000	1250	MHz
RF Input Frequency Range	0.5		18	GHz
Instantaneous Usable Bandwidth		500		MHz
IF Ripple (+/- 250 MHz)		5		dB
Gain, 0.5-18 GHz, Atten= 0 dB, Mode = 1	10		35	dB
Gain, 0.5-18 GHz, Atten= 0 dB, Mode = 2	25		50	dB
Gain, 0.5-18 GHz, Atten= 0 dB, Mode = 3	25		50	dB
Gain, 0.5-18 GHz, Atten= 0 dB, Mode = 4	40		65	dB
Noise Figure (NF), Atten= 0 dB		6.8		dB
Input P1dB, 0.5-18 GHz, Atten= 0 dB, Mode = 1	-20		5	dBm
Input P1dB, 0.5-18 GHz, Atten= 0 dB, Mode = 2	-35		-10	dBm
Input P1dB, 0.5-18 GHz, Atten= 0 dB, Mode = 3	-35		-10	dBm
Input P1dB, 0.5-18 GHz, Atten= 0 dB, Mode = 4	-50		-25	dBm
Output P1dB, 0.5-18 GHz, Atten= 0 dB		15		dBm
Phase Noise, 1 KHz Offset		-72		dBc/Hz
Phase Noise, 10 KHz Offset		-77		dBc/Hz
Phase Noise, 100 KHz Offset		-77		dBc/Hz
In-Band Spurious, +/- 250 MHz		-50		dBc
SFDR (Two-tone test)		50		dB

For price, delivery, and to place orders, please contact Quonset Microwave:  
315 Commerce Park Road, North Kingstown, RI 02852 Phone: 401-295-0062



**Quonset Microwave**  
www.quonsetmicrowave.com

**QM1003-0.5-18-X**  
**0.5-18 GHz Wideband RF**  
**Downconverter**

**Electrical Specifications - Option 204**

Parameter	Min.	Typ.	Max.	Units
IF Output Center Frequency	100	600	1100	MHz
RF Input Frequency Range	0.5		18	GHz
Instantaneous Usable Bandwidth		1000		MHz
IF Ripple (+/- 250 MHz)		5		dB
Gain, 0.5-18 GHz, Atten= 0 dB		45		dB
Noise Figure (NF), Atten= 0 dB		6.8		dB
Input P1dB, 0.5-18 GHz, Atten= 0 dB		-40		dBm
Output P1dB, 0.5-18 GHz, Atten= 0 dB		13		dBm
Phase Noise, 1 KHz Offset		-72		dBc/Hz
Phase Noise, 10 KHz Offset		-77		dBc/Hz
Phase Noise, 100 KHz Offset		-77		dBc/Hz
Phase Noise, 1 MHz Offset		-105		dBc/Hz
Phase Noise, 10 MHz Offset		-117		dBc/Hz
In-Band Spurious, +/- 250 MHz		-50		dBc
SFDR (Two-tone test)		50		dB

For price, delivery, and to place orders, please contact Quonset Microwave:  
315 Commerce Park Road, North Kingstown, RI 02852 Phone: 401-295-0062



**Quonset Microwave**  
www.quonsetmicrowave.com

**QM1003-0.5-18-X**  
**0.5-18 GHz Wideband RF**  
**Downconverter**

**Electrical Specifications - Option 205**

Parameter	Min.	Typ.	Max.	Units
IF Output Center Frequency	2000	2500	3000	MHz
RF Input Frequency Range	0.5		18	GHz
Instantaneous Usable Bandwidth		500		MHz
IF Ripple (+/- 250 MHz)		5		dB
Gain, 0.5-18 GHz, Atten= 0 dB		45		dB
Noise Figure (NF), Atten= 0 dB		6.8		dB
Input P1dB, 0.5-18 GHz, Atten= 0 dB		-40		dBm
Output P1dB, 0.5-18 GHz, Atten= 0 dB		13		dBm
Phase Noise, 1 KHz Offset		-72		dBc/Hz
Phase Noise, 10 KHz Offset		-77		dBc/Hz
Phase Noise, 100 KHz Offset		-77		dBc/Hz
Phase Noise, 1 MHz Offset		-105		dBc/Hz
Phase Noise, 10 MHz Offset		-117		dBc/Hz
In-Band Spurious, +/- 250 MHz		-50		dBc
SFDR (Two-tone test)		50		dB

For price, delivery, and to place orders, please contact Quonset Microwave:  
315 Commerce Park Road, North Kingstown, RI 02852 Phone: 401-295-0062



**Electrical Specifications - Option 206**

Parameter	Min.	Typ.	Max.	Units
IF Output Center Frequency	500	1000	1500	MHz
RF Input Frequency Range	0.5		18	GHz
Instantaneous Usable Bandwidth		1000		MHz
IF Ripple (+/- 500 MHz)		5		dB
Gain, 1.5 GHz, IF Output Amp = Off		35		dB
Gain, 9.25 GHz, IF Output Amp = Off		25		dB
Gain, 17 GHz, IF Output Amp = Off		15		dB
Gain, 1.5 GHz, IF Output Amp = On		50		dB
Gain, 9.25 GHz, IF Output Amp = On		40		dB
Gain, 17 GHz, IF Output Amp = On		30		dB
Noise Figure (NF), Atten= 0 dB		6.8		dB
Input P1dB, 1.5 GHz, IF Output Amp = Off		-17		dBm
Input P1dB, 9.25 GHz, IF Output Amp = Off		-7		dBm
Input P1dB, 17 GHz, IF Output Amp = Off		-3		dBm
Output P1dB, 0.5-18 GHz, IF Output Amp = Off		18		dBm
Input P1dB, 1.5 GHz, IF Output Amp = On		-35		dBm
Input P1dB, 9.25 GHz, IF Output Amp = On		-35		dBm
Input P1dB, 17 GHz, IF Output Amp = On		-15		dBm
Output P1dB, 0.5-18 GHz, IF Output Amp = On		15		dBm
Output P1dB, 0.5-18 GHz, Atten= 0 dB		13		dBm
Phase Noise, 1 KHz Offset		-72		dBc/Hz
Phase Noise, 10 KHz Offset		-77		dBc/Hz
Phase Noise, 100 KHz Offset		-77		dBc/Hz
Phase Noise, 1 MHz Offset		-105		dBc/Hz
Phase Noise, 10 MHz Offset		-117		dBc/Hz
In-Band Spurious, +/- 500 MHz		-50		dBc
SFDR (Two-tone test)		50		dB



**Quonset Microwave**  
www.quonsetmicrowave.com

**QM1003-0.5-18-X**  
**0.5-18 GHz Wideband RF**  
**Downconverter**

**Common Specifications**

Parameter	Min.	Typ.	Max.	Units
Operating Voltage		+15		VDC
Current Draw			5	Amps
Tune Frequency Step Size				
Integer Mode*		400		MHz
Fractional Mode		100		KHz
LO1 Input Frequency Range	21.5		39	GHz
LO1 Input Power		0		dBm
External Reference Input	10		250	MHz
External Reference 1 Output		10		MHz





### Options Overview

To provide flexibility for system integration, the QM1003-0.5-18-X series of downconverters has multiple configuration options that pertain to three categories – (1) Local Oscillator (LO) generation, (2) Independent vs. common channel control for dual channel systems, (3) IF frequency modifications. An internal common LO (Option 100) is not included with the Base system.

To select options related to LO generation and independent/common channel control, the following option codes are provided.

Option Code	Description
100 (Base System)	With the Base System (Option 100), a common LO1 and LO2 are included in the unit. Both a USB Type-A connector and an RJ-45 (TCP/IP) connector are added to the back panel for LO control. In dual channel systems with the Base Option Code 100 selected, LOs are common, meaning both channels (up- and downconversion) are always tuned to the same frequency.
110	When Option 110 is specified, separate independent LOs are included for the downconverter channels if two channels are included.
200	The IF input/output is 50-550 MHz with an instantaneous bandwidth of 500 MHz.
201	The IF input/output is 750-1250 MHz with an instantaneous bandwidth of 500 MHz.
204	The IF input/output is 100-1100 MHz with an instantaneous bandwidth of 1 GHz.
205	The IF input/output is 2000-3000 MHz with an instantaneous bandwidth of 1 GHz.
206	The IF input/output is 500-1500 MHz with an instantaneous bandwidth of 1 GHz.



**QM1003 Series System Block Diagrams**

For the Base System (**Option 100**), LO1 and LO2 frequencies are generated internally. The LOs are PLL based and require a reference clock and digital control. Figure 1 depicts the system elements for the Base System (Option 100) with internal LOs. The LOs are controlled digitally via a microcontroller, which interfaces to a PC through USB or TCP/IP. The microcontroller outputs basic status messages on a 32-character Liquid Crystal Display (LCD) mounted on the faceplate of the unit. An internal low phase noise 20 MHz reference clock is phase-locked to all of the internal the LOs, with a BNC-F connector providing the option for LOs to lock to a user-provided external reference in the range of 10-100 MHz. A second BNC-F connector outputs an internally-generated 100 MHz reference is used by the LOs for daisy chaining multiple pieces of equipment. Switching between the internal and external LO reference clocks is controlled by the microcontroller and a reference selector switch. The LO1 signal may be provided externally, and the selection between internal and external LO1 is provided by a back-panel switch. A DB-25 connector is provided on the back panel for optional fast-tuning that is controlled by an external TTL signal.

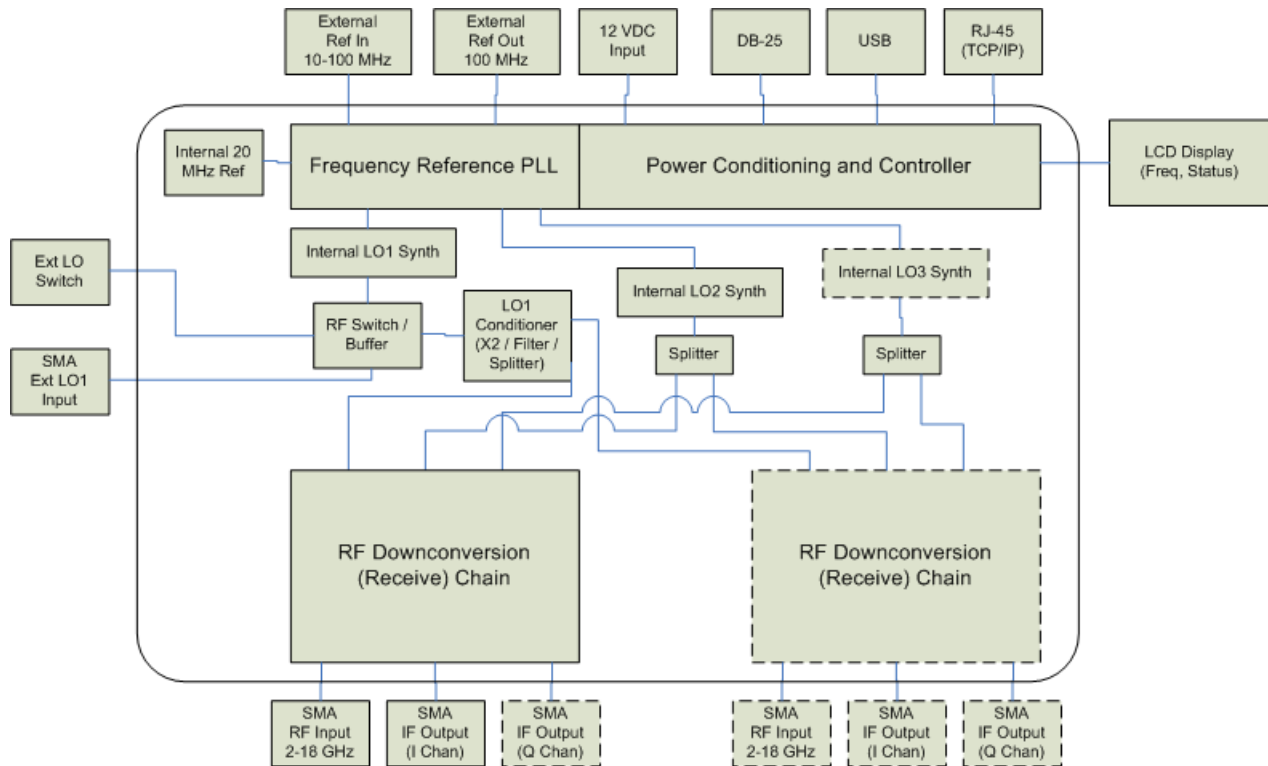

**Figure 1. QM1003-0.5-18 block diagram for the Base System (Option 100) with optional third LO for optional third conversion stage (Options 200/204) shown in dashed line.**

**RF Signal Chain**

QM1003 Series Wideband RF Downconverters use a dual stage conversion architecture to convert RF frequencies to a 1 GHz center-frequency IF (or 300 MHz with Option 200, 600 MHz with Option 204, and 2.5 GHz with Option 205) to an RF centered between 0.5 and 18 GHz. For details on the RF conversion signal chain, please contact sales@quonsetmicrowave.com.



In order to control the RF transmit/receive frequency, the internal LO1 synthesizer is tuned using either the provided Windows GUI or using VISA interface commands. Optionally, an external LO1 signal may be provided between 21.5 and 39 GHz (22.5 – 40 GHz with Option 200).

Using the internal LOs, the LO1 frequency calculation is performed internally, and the user need only digitally choose their desired transmit/receive frequency. Otherwise, the LO1 input frequency can be calculated using the desired RF tune frequency + 21 or + 22 in case of Option 200.

### Option 200/201 RF Chain Modifications

Option 200 moves the IF from 750-1250 MHz down to 50-550 MHz. This modification requires a third frequency conversion stage which converts the 1 GHz output IF to an IF output frequency centered at 300 MHz (Option 200). As with all QM1003 series downconverter units, knowledge of the LO input frequencies and frequency plan calculation is only necessary if user-generated external LOs are required.

### Controlling QM1003 Downconverters with Internal LOs (Option 100)

QM1003 Downconverters with internal LOs have been designed to be VISA and USBTMC compliant. Any PC and operating system with Virtual Instrument Software Architecture (VISA) drivers installed should be able to communicate with QM1003 units. VISA drivers are provided by many Test and Measurement companies, including Agilent Technologies, National Instruments, and Tektronix. USB and TCP/IP communication and command structure is discussed in detail in the frequency conversion programming manual. A lightweight GUI, supported in Windows®, will be provided for units with internal LOs, providing control of all commonly used commands.

### Interface Connections

The necessary front and back panel input/output connections on a QM1003 Series frequency converter are summarized in Table 1. The front-panel connections are shown in Figure 2 while the rear-panel connections are shown in Figure 3. Interface connections for the optional Outdoor Unit are similar.



Figure 2. Front panel connections to QM1003-0.5-18.



Figure 3. Rear-panel connections to QM1003-0.5-18.

Table 1. Input and output connections for QM1003-0.5-18-X (19" Rack Form-Factor)



**Quonset Microwave**  
www.quonsetmicrowave.com

**QM1003-0.5-18-X**  
**0.5-18 GHz Wideband RF**  
**Downconverter**

Parameter	Connector Style	Type	Location
Upconverter IF Input	SMA	Female	Front Panel
Upconverter RF Output	SMA	Female	Front Panel
Downconverter RF Input	SMA	Female	Front Panel
Downconverter IF (I) Output	SMA	Female	Front Panel
Downconverter IF (Q) Output	SMA	Female	Front Panel
Reference Input (10-100 MHz)	BNC	Female	Rear Panel
Reference 1 Output (100 MHz)	BNC	Female	Rear Panel
Reference 2 Output (10 MHz)	BNC	Female	Rear Panel
LO1 Input (21.5-39 GHz)	2.92mm	Female	Front Panel
LO1 Int/Ext Switch	Toggle	SPDT Switch	Rear Panel
Int/Ext Ref Switch	Toggle	SPDT Switch	Rear Panel
USB/Ethernet Combined	RJ-45 (Ethernet) Type-A (USB)	Female	Rear Panel
Power Jack	2.1 mm Barrel	Male	Rear Panel
TTL Input (Frequency Tuning, Attenuation Control, Lock Status)	DB-44 (Formerly DB-25)	Female	Rear Panel

**Power Interface**

The QM1003 Downconverter requires a DC input voltage of 15V applied at the 5.5mm power jack (2.5mm barrel) on the back panel of the instrument. An AC-DC power adapter is supplied with the unit.

**Absolute Maximums**

Operating Temperature	+40 °C
RF Input Power	+2 dBm



**ELECTROSTATIC SENSITIVE DEVICE**  
**OBSERVE HANDLING PRECAUTIONS**

**Ordering Information**

QM1003-0.5-18-X-[Options]-[ODU]

where

X= 1, 2 (# of Channels)

Options= 100, 110, 200, 201, etc.

ODU= Optional Outdoor Unit Form-Factor

For price, delivery, and to place orders, please contact Quonset Microwave:  
315 Commerce Park Road, North Kingstown, RI 02852 Phone: 401-295-0062